



# SECTIONALIZING ENCLOSURES

---

SINGLE & THREE-PHASE



---

**ALUMA-FORM** specializes in innovative,  
custom-engineered overhead utility and  
communications solutions.

---

---

# WE ARE ALUMA-FORM®

## WE ARE **QUALITY PARTS**

---

Our reputation for excellence is based on 50 years of manufacturing done right and we bring that experience to every industry-leading product we design and manufacture.

## WE ARE **INNOVATIVE SOLUTIONS**

---

Our engineering teams have an extensive range of expertise and are equipped with the latest in product development and manufacturing technology so our customers get the most innovative solutions possible.

## WE ARE **SUPERIOR SUPPORT**

---

Our unique management-owned structure and lean management style means that our customers get the support and attention they need.

# OUR PRESENCE

---



## MEMPHIS, TN

---

260,000 square foot facility:

- 160,000 square feet for manufacturing
- 100,000 square feet for raw material storage

## WALNUT, MS

---

200,000 square foot facility:

- 80,000 square feet for manufacturing
- 120,000 square feet for raw material storage



## COPE, SC

---

180,000 square foot facility:

- 60,000 square feet for manufacturing
- 120,000 square feet for raw material storage

## CALGARY, ALBERTA

---

65,000 square foot facility:

- 35,000 square feet for manufacturing
- 30,000 square feet for raw material storage

# GLOBAL CAPABILITIES

---

As an industry leader we continue to design, develop, and engineer new products for the utility market. From our plants in North America we are able to provide materials all over the world. With projects and distribution channels on almost every continent Aluma-Form products are helping power the world.





Our dedicated highly responsive Customer Service, 100,000 square foot Fulfillment Center, and Dedicated Storm Stock at all our plants makes Aluma-Form the manufacturer of choice for our customers during an emergency.

## 24 HOUR SERVICE

Our customer service representatives are available 24 Hours a Day, 365 Days a Year to provide support and coverage during storms and natural disasters.

## BEST-IN-CLASS FULFILLMENT

The Storm Team turns around orders fast. Our 100,000 square foot fulfillment center and dedicated staff use best in class practices and a wide range of transportation partners to delivery product fast and accurately to our customers.

## DEDICATED STORM INVENTORY

We rigorously plan and assess our inventory throughout the year to meet customer demand and carry enough excess inventory in case of an emergency.

Each of our facilities carries dedicated storm inventory making sure that no matter what happens, Aluma-Form can respond.

CALGARY, AB

MEMPHIS, TN

COPE, SC

WALNUT, MS



---

# STEEL ENCLOSURES

---



# STEEL ENCLOSURES

Aluma-Form's versatile single and three-phase enclosures provide durable, low-profile installations for sectionalizing, tapping, or terminating underground cable. Our enclosures' fully welded 14 or 12 gauge mild steel construction provides a safe and sturdy product at a competitive price.

**Standard Windstop**  
*for safety*

**Barrel Top Hinge**  
*easy access to electrical components*

**Stainless Steel Penta-Head Bolt(s)**  
*meets ANSI C57.12.28 for tamperproof*

**Fully Welded Seams**

**Stainless Steel Lifting Provisions**  
*for easy installation*

**All Steel Construction**  
*for superior strength*

**Light Grey Junction Mounting Bars**

**Durable Powder Coated Finish**  
*Munsell Green - Exceeds ANSI Standards*

**Included Grounding Nuts**  
*on mounting bar and back wall*

**Made In America**



Aluma-Form's enclosures are made in the United States using the latest in manufacturing technology



## SINGLE PHASE ENCLOSURES

### OVERVIEW

Completely welded **steel construction** provides a safe and durable design at a competitive price. Available for use on single-phase systems that are rated **200A** or **600A** and **15kV** through **35kV**.

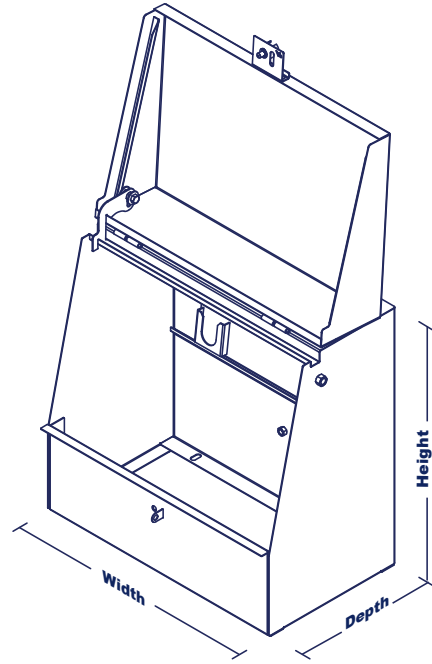

AF CAT #	DESCRIPTION	MATERIAL	HEIGHT (IN)	WIDTH (IN)	DEPTH (IN)
ENC-SC1-302618-S1-G	<b>ENCLOSURE SECTIONALIZING</b> 1PH 18D x 26W x 30H STD GAUGE	14 Gauge Steel	30	26	18
ENC-SC1-303018-S1-G	<b>ENCLOSURE SECTIONALIZING</b> 1PH 18D X 30W X 30H STD GAUGE	14 Gauge Steel	30	30	18
ENC-SC1-303622-S2-G	<b>ENCLOSURE SECTIONALIZING</b> 1PH 22D X 36W X 30H HVY GAUGE	12 Gauge Steel	30	36	22



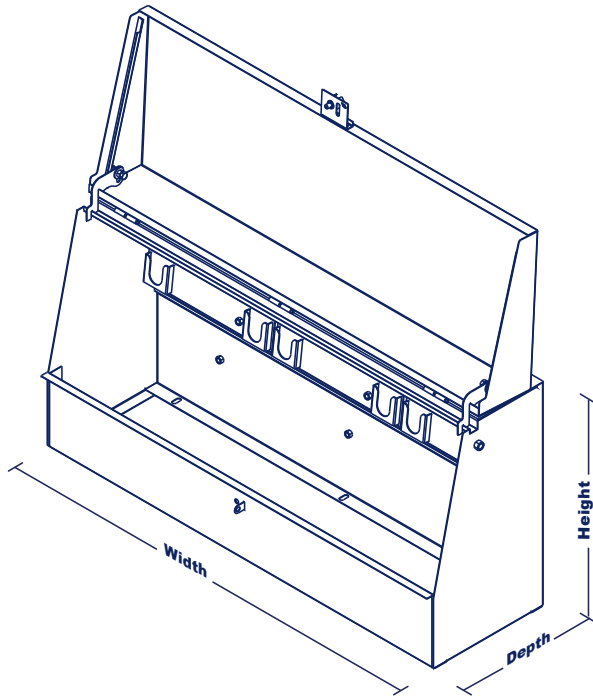

## THREE PHASE ENCLOSURES

### OVERVIEW

Completely welded **steel construction** provides a safe and durable design at a competitive price. Available for use on three-phase systems that are rated **200A** or **600A** and **15kV** through **35kV**.

AF CAT #	DESCRIPTION	MATERIAL	HEIGHT (IN)	WIDTH (IN)	DEPTH (IN)
ENC-SC3-304822-S2-G	<b>ENCLOSURE SECTIONALIZING</b> 3PH 22D X 48W X 30H HVY GAUGE	12 Gauge Steel	30	48	22
ENC-SC3-304824-S2-G	<b>ENCLOSURE SECTIONALIZING</b> 3PH 24D X 48W X 30H HVY GAUGE	12 Gauge Steel	30	48	24
ENC-SC3-306018-S1-G	<b>ENCLOSURE SECTIONALIZING</b> 3PH 18D X 60W X 30H STD GAUGE	14 Gauge Steel	30	60	18
ENC-SC3-306622-S2-G	<b>ENCLOSURE SECTIONALIZING</b> 3PH 22D X 66W X 30H HVY GAUGE	12 Gauge Steel	30	66	22



---

# ALUMINUM ENCLOSURES

---

# ALUMINUM ENCLOSURES

Aluma-Form's versatile single and three-phase enclosures provide lightweight, low-profile installations for sectionalizing, tapping, or terminating underground cable. Our enclosures' fully welded aluminum construction provides a safe and durable alternative to steel at a competitive price all while having superior weatherability and a much lighter overall weight.

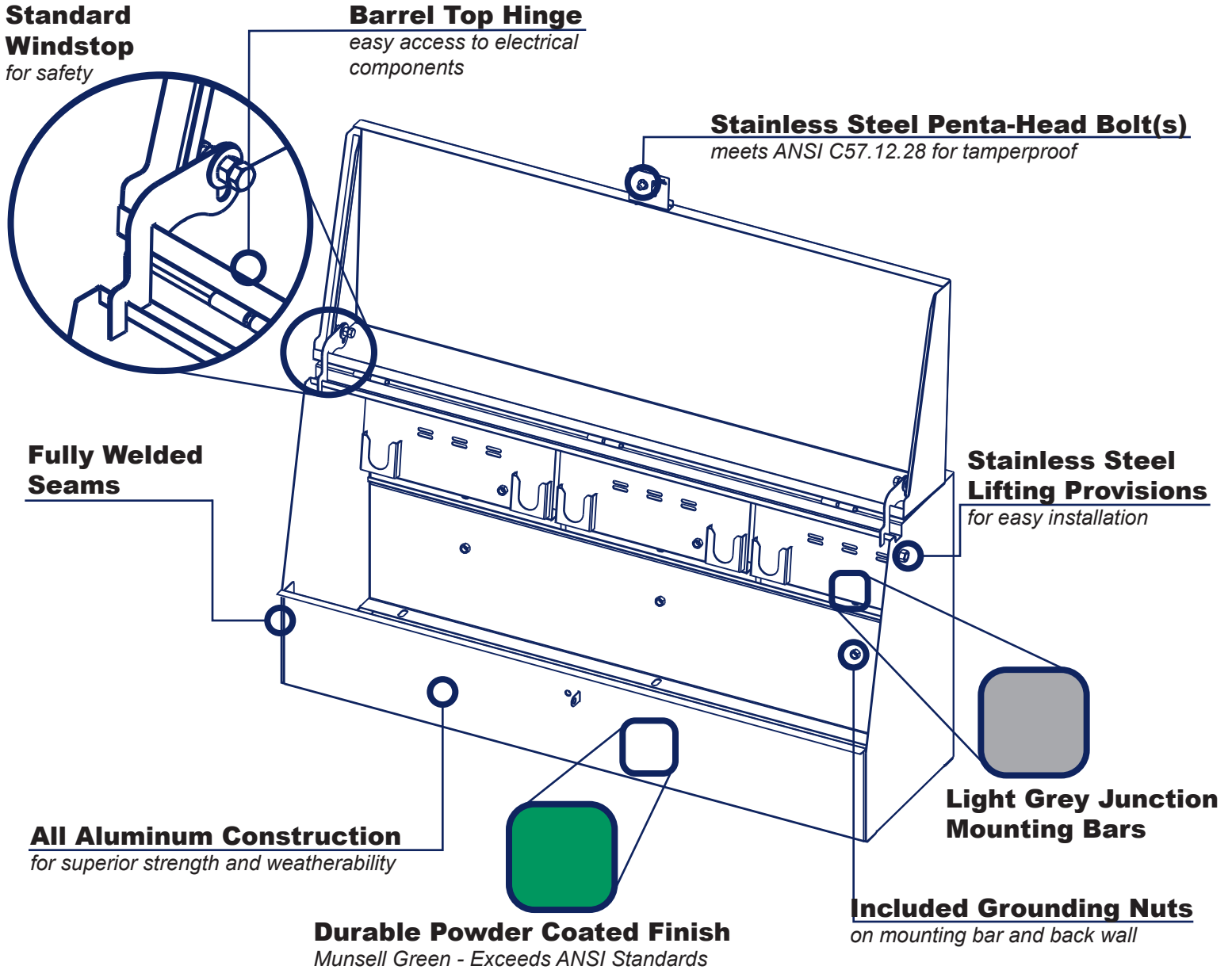

## Made In America



Aluma-Form's enclosures are made in the United States using the latest in manufacturing technology



## SINGLE PHASE ENCLOSURES

### OVERVIEW

Completely welded **aluminum construction** provides a safe, light and durable design at a price that is competitive with steel. Available for use on single-phase systems that are rated **200A** or **600A** and **15kV** through **35kV**.

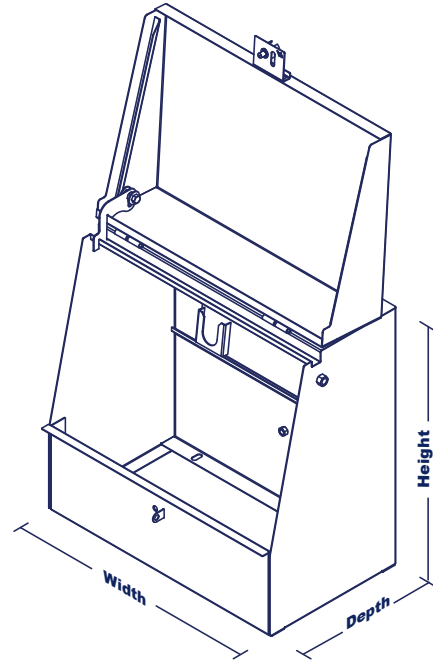

AF CAT #	DESCRIPTION	MATERIAL	HEIGHT (IN)	WIDTH (IN)	DEPTH (IN)
ENC-SC1-302618-A1-G	<b>ENCLOSURE SECTIONALIZING</b> 1PH 18D x 26W x 30H STD GAUGE	.090" Aluminum	30	26	18
ENC-SC1-303018-A1-G	<b>ENCLOSURE SECTIONALIZING</b> 1PH 18D X 30W X 30H STD GAUGE	.090" Aluminum	30	30	18
ENC-SC1-303622-A2-G	<b>ENCLOSURE SECTIONALIZING</b> 1PH 22D X 36W X 30H HVY GAUGE	.125" Aluminum	30	36	22

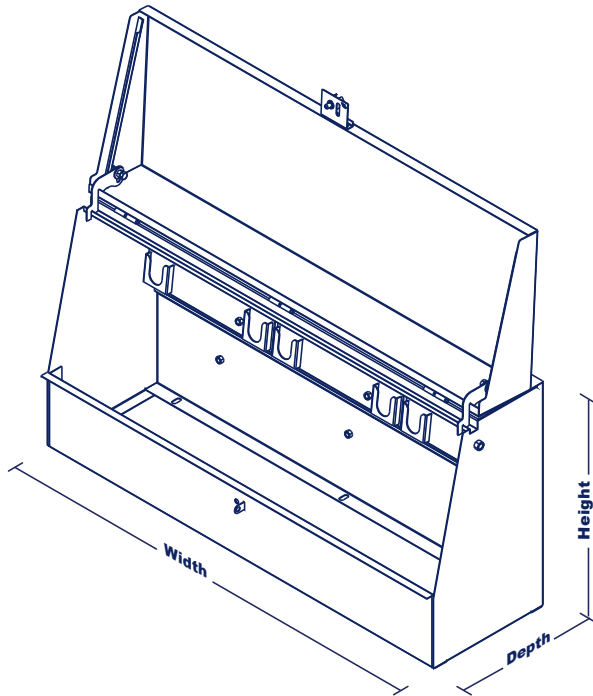

## THREE PHASE ENCLOSURES

### OVERVIEW

Completely welded **aluminum construction** provides a safe, light and durable design at a price that is competitive with steel. Available for use on three-phase systems that are rated **200A** or **600A** and **15kV** through **35kV**.

AF CAT #	DESCRIPTION	MATERIAL	HEIGHT (IN)	WIDTH (IN)	DEPTH (IN)
ENC-SC3-304822-A2-G	<b>ENCLOSURE SECTIONALIZING</b> 3PH 22D X 48W X 30H HVY GAUGE	.125" Aluminum	30	48	22
ENC-SC3-304824-A2-G	<b>ENCLOSURE SECTIONALIZING</b> 3PH 24D X 48W X 30H HVY GAUGE	.125" Aluminum	30	48	24
ENC-SC3-306018-A1-G	<b>ENCLOSURE SECTIONALIZING</b> 3PH 18D X 60W X 30H STD GAUGE	.090" Aluminum	30	60	18
ENC-SC3-306622-A2-G	<b>ENCLOSURE SECTIONALIZING</b> 3PH 22D X 66W X 30H HVY GAUGE	.125" Aluminum	30	66	22

# ENCLOSURE CATALOG LEGEND

Custom enclosures are available. Aluma-Form can provide alternate colors and modified dimensions. Please contact your local sales representative for details.

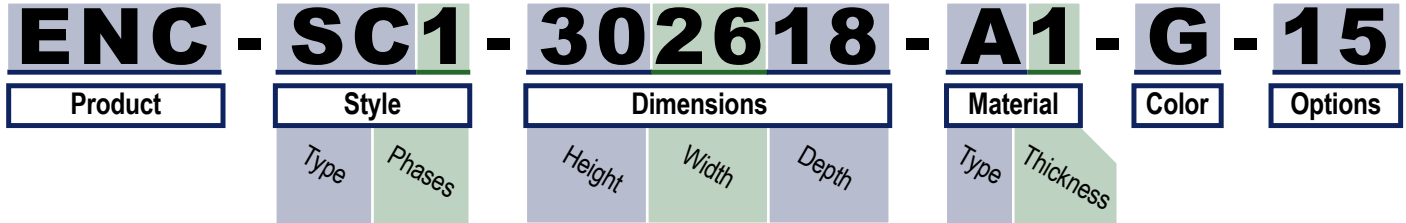

## ENCLOSURE CUSTOMIZATIONS

STYLE		DIMENSIONS			MATERIAL		COLOR	OPTIONS
TYPE	PHASES	HEIGHT	WIDTH	DEPTH	TYPE	THICKNESS		
<b>SC</b> Sectionalizing Cabinet	<b>1</b> Single Phase	<b>24</b> 24"	<b>26</b> 26"	<b>18</b> 18"	<b>A</b> Aluminum	<b>1</b> Std Gauge	<b>G</b> Munsell Green <b>1</b> ANSI 70 Gray	<b>Blank</b> None <b>15</b> 15kV Junction <b>25</b> 25kV Junction <b>35</b> 35kV Junction
	<b>3</b> Three Phase	<b>30</b> 30" <b>33</b> 33" <b>36</b> 36"	<b>30</b> 30" <b>36</b> 36" <b>48</b> 48" <b>60</b> 60" <b>66</b> 66" <b>78</b> 78" <b>84</b> 84" <b>98</b> 98"	<b>22</b> 22" <b>24</b> 24" <b>30</b> 30"	<b>S</b> Mild Steel <b>SS</b> Stainless Steel	<b>1</b> Aluminum: .090" Steel: 14 Gauge <b>2</b> Heavy Gauge Aluminum: .125" Steel: 12 Gauge		



**ALUMA-FORM®**

Aluma-Form, Inc.  
3625 Old Getwell Rd.  
Memphis TN 38118  
901-362-0100  
Fax: 901-794-9515

©2020 Aluma-Form, Inc.